

**TENTATIVE MAP INFORMATION**

**APPLICANT:** WP Sierra View, LLC  
1420 Rocky Ridge Drive, Suite 265  
Roseville, CA 95661

**OWNER:** SVLC 23, LLC

**ENGINEER:** MacKay & Samps Civil Engineers, Inc.  
1025 Creekside Ridge Drive, Suite 150  
Roseville, CA 95678  
916-773-1189

**SITE ADDRESS:** 360 Diamond Oaks Road  
Roseville, CA 95678

**ASSESSOR'S PARCEL NUMBER:** 015-011-029

**SITE AREA:** 23.10 ± AC.

**GENERAL PLAN LAND USE:**  
Existing: LDR & MDR  
Proposed: LDR

**ZONING:**  
Existing: R1 & R3  
Proposed: RS/DS

**NUMBER OF LOTS/PARCELS:** 86 TOTAL LOTS  
75 LDR Lots  
4 Landscape / Detention Lots  
5 Landscape Lots  
1 Open Space Lot  
1 Private Park Lot

**SERVICE PROVIDERS:**  
Parks & Recreation: City of Roseville  
Police & Fire Protection: City of Roseville  
Sanitary Sewer: City of Roseville  
Domestic & Recycled Water: City of Roseville  
Electricity: City of Roseville  
AT&T & Consolidated Communications  
Gas: PG&E  
Cable: Comcast/Consolidated Communications

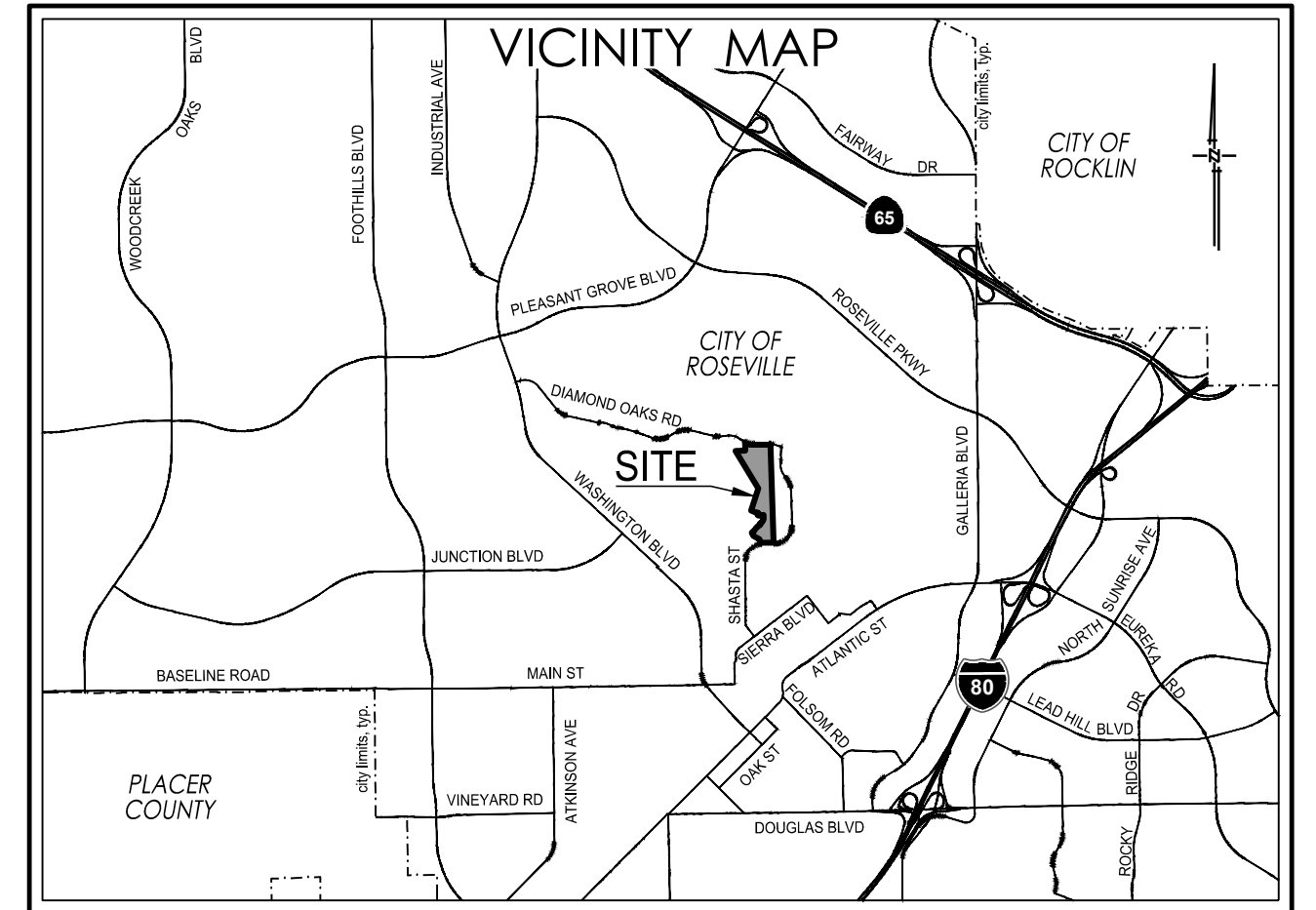

**TENTATIVE MAP NOTES**

- PROPERTY DESCRIPTION:** The land described herein is situated in the state of California, County of Placer, City of Roseville, described as follows: Parcel 1 of Sierra View Parcel Map #2, Subdivision No. 000142, filed for record May 3, 2013, in Book 35 of Parcel Maps, at Page 46. Together with that portion of Resultant Parcel 2 of Lot Line Adjustment filed for record March 5, 2013, in Document No. 2013-0021343, Official Records, Placer County; more particularly described as follows:  
Beginning at a point being the Southeast corner of said Resultant Parcel 2 of Lot Line Adjustment filed for record March 5, 2013, in Document No. 2013-0021343, Official Records, Placer County and also being the Northeast corner of Parcel 1 of Sierra View Parcel Map #2, Subdivision No. 000142, filed for record May 3, 2013, in Book 35 of Parcel Maps, at Page 46; thence North 00°09'20" East 125.00 feet to the Southern right of way of Diamond Oaks Road; thence along said right of way, the following four (4) courses:  
1) North 89°50'40" West 2.13 feet to a point of cusp with a non-tangent curve, concave South, having a radius of 373.00 feet, the initial radial of which bears North 09°32'51" East;  
2) Along said curve an arc distance of 61.14 feet through a central angle of 09°23'31"; said curve being subtended by a chord bearing North 85°08'54" West 61.07 feet, a radial to said point which bears North 00°09'20" East;  
3) North 89°50'40" West 307.36 feet to the beginning of a tangent curve, concave North, having a radius of 527.00 feet;  
4) Along said curve an arc distance of 213.35 feet, through a central angle of 23°11'42", said curve being subtended by a chord bearing North 78°14'48" West 211.89 feet, a radial to said point which bears South 29°21'03" West being the northeast corner of Resultant Parcel 1 of Lot Line Adjustment filed for record March 5, 2013, in Document No. 2013-0021343, Official Records, Placer County;  
thence along easterly lot line of said Resultant Parcel 1 of Lot Line Adjustment filed for record March 5, 2013, in Document No. 2013-0021343, Official Records, Placer County South 00°09'20" West 47.60 feet to the Southeast corner of said Resultant Parcel 1; thence South 00°09'20" West 125.07 feet to a point on the Northern boundary line of Parcel 1 of Sierra View Parcel Map #2, Subdivision No. 000142, filed for record May 3, 2013, in Book 35 of Parcel Maps, at Page 46; thence along said Northern boundary line South 89°51'05" East 577.92 feet back to the Point of Beginning.  
The above legal description is made pursuant to that certain Lot Line Adjustment and Certificate of Compliance recorded March 4, 2014, Instrument No. 2014-0014272, Official Records, and being Resultant Parcel 1 as described therein.  
Reserving therefrom, a 50' Private Access Easement for the benefit of the Remainder Parcel, as shown on said Parcel Map entitled Sierra View Parcel Map #2, Subdivision No. 000142, filed for record May 3, 2013, in Book 35 of Parcel Maps, at Page 46.
- Lot dimensions and acreages are approximate and are subject to change.
- Lot lines and lot areas may be adjusted at the time of Final Map(s) preparation provided no additional lots are created, subject to approval by the City of Roseville.
- The Final Mapping and subsequent development of parcels and streets may be phased. Project improvements are deferred to individual Small Lot Final Maps or project development plans.
- Pursuant to Government Code Section 66463.1, the subdivider may file multiple Final Maps based upon this Tentative Subdivision Map. The filing of a Final Map on a portion of this Tentative Subdivision Map shall not invalidate any part of this Tentative Subdivision Map.
- The Final Mapping and subsequent development of parcels and streets may be phased. Phasing is to be consistent with the applicable infrastructure phasing matrix.
- Additional easements to accommodate new public utility improvements, access required for parcel development, rights to construct, or other similar mapping requirements needed to accomplish the final design may be added prior to each Small Lot Final Map based on this Tentative Subdivision Map.
- Pursuant to California Government Code Section 66499.20.2, the land shown hereon may be merged and resubdivided without reversion to acreage and may constitute abandonment of portions of the existing easements, subject to the approval of the City of Roseville, including the following:  
a. A 10' wide P.U.E. per 35 P.M. 46.  
b. A 50' private access easement per 35 P.M. 46.  
c. An access and utility easement per 937 O.R. 692.  
d. A 10' wide drainage easement per 2583 O.R. 163.
- A minimum 10' Public Utility Public Easement (PUE) will be located adjacent to all rights-of-way unless otherwise noted.
- The following lots are to be dedicated to the Sierra Townhomes HOA with the corresponding phase of the time of each Final Map: Lots L, J and K.
- Landscape lots and open space lots are not to be counted as "lots" towards any future boundary line adjustment.
- Sierra View will be a gated community, an HOA will be formed for the maintenance of the following lots A, B, C, D, E, F, G and H and private roads within this project.
- This project will contain private streets and drainage systems. Water and Sewer will be public service.

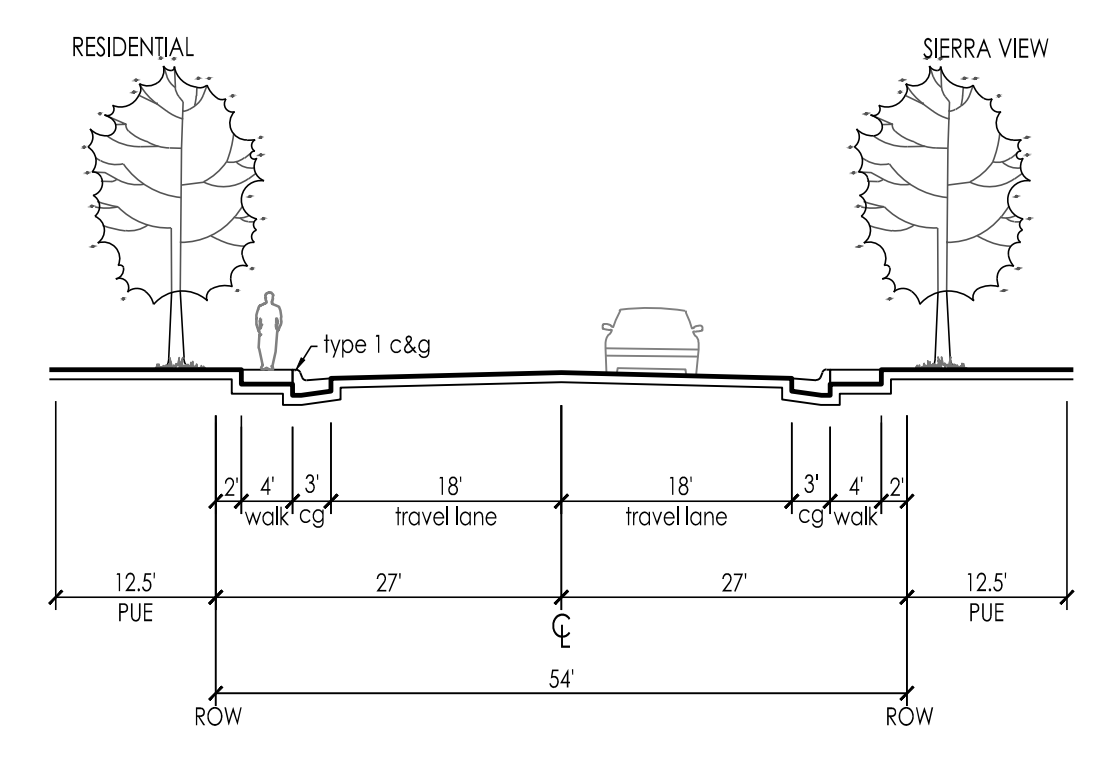

**A DIAMOND OAKS ROAD**  
54' ROW  
n.t.s.

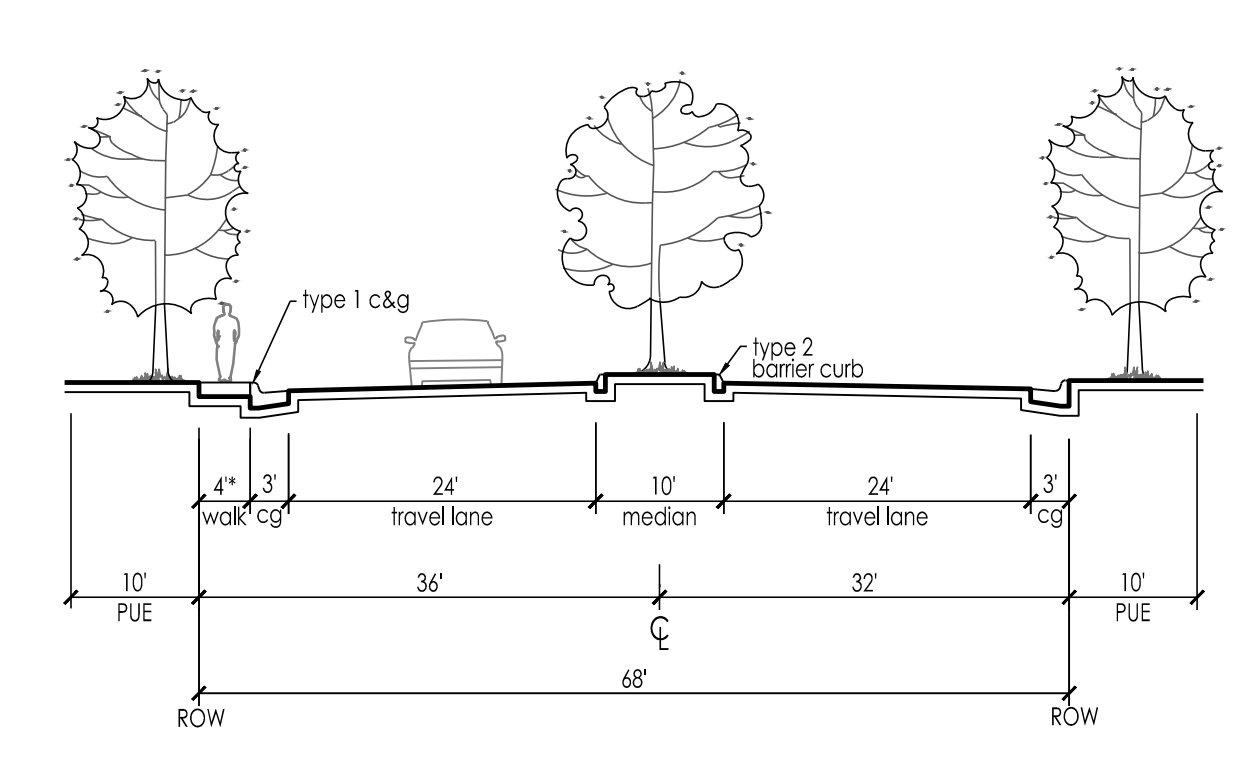

**B RESIDENTIAL ENTRY**  
(MODIFIED CITY OF ROSEVILLE STD. DWG ST-25)  
n.t.s.  
\* Sidewalk may be detached to accommodate gated entry.

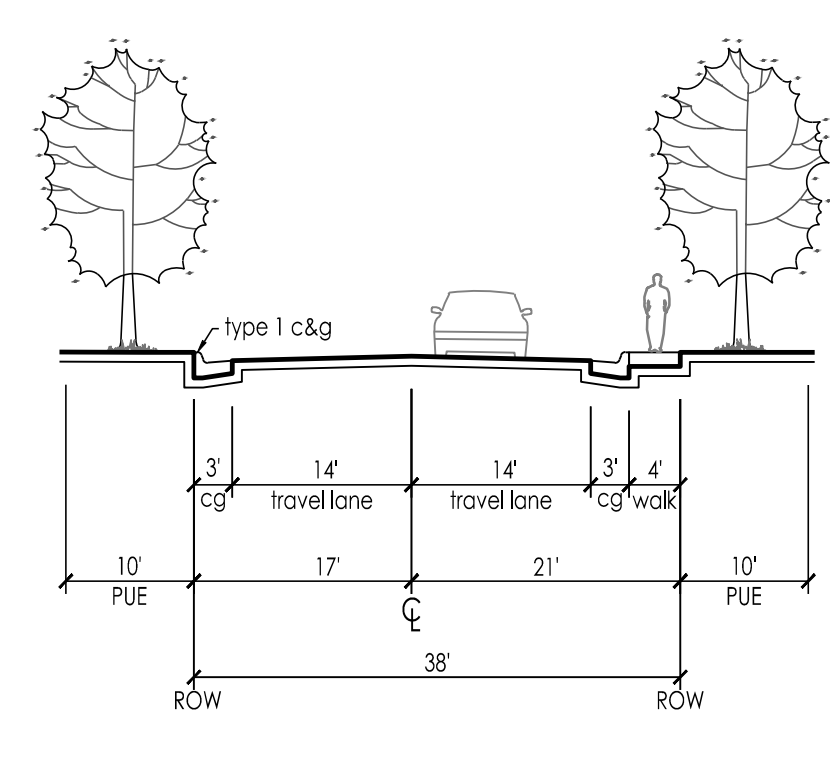

**C MINOR RESIDENTIAL STREET**  
(MODIFIED CITY OF ROSEVILLE STD. DWG ST-2)  
n.t.s.

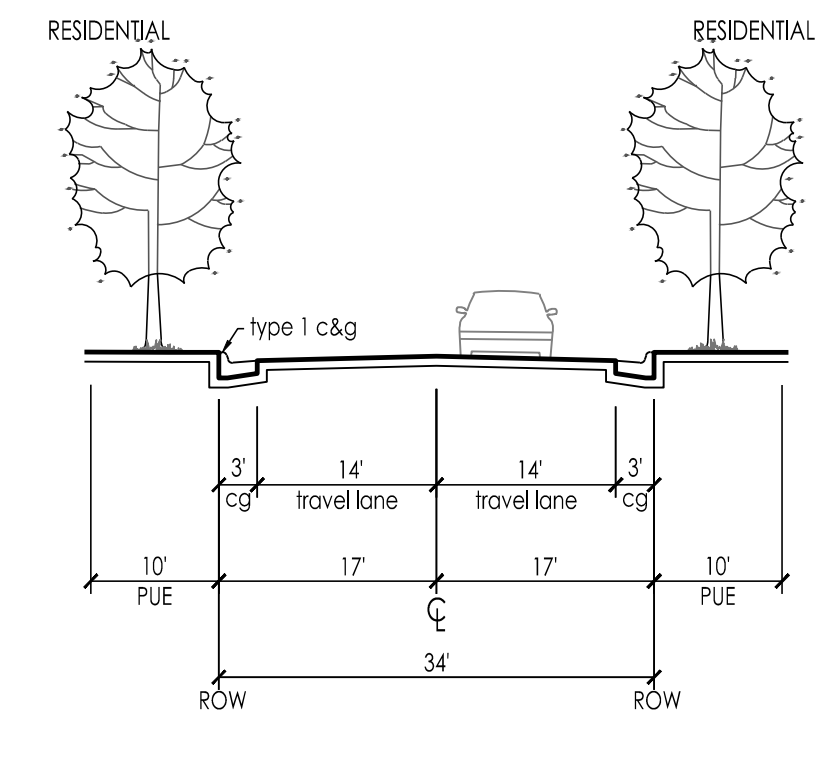

**D SAWGRASS PLACE**  
34' ROW  
n.t.s.

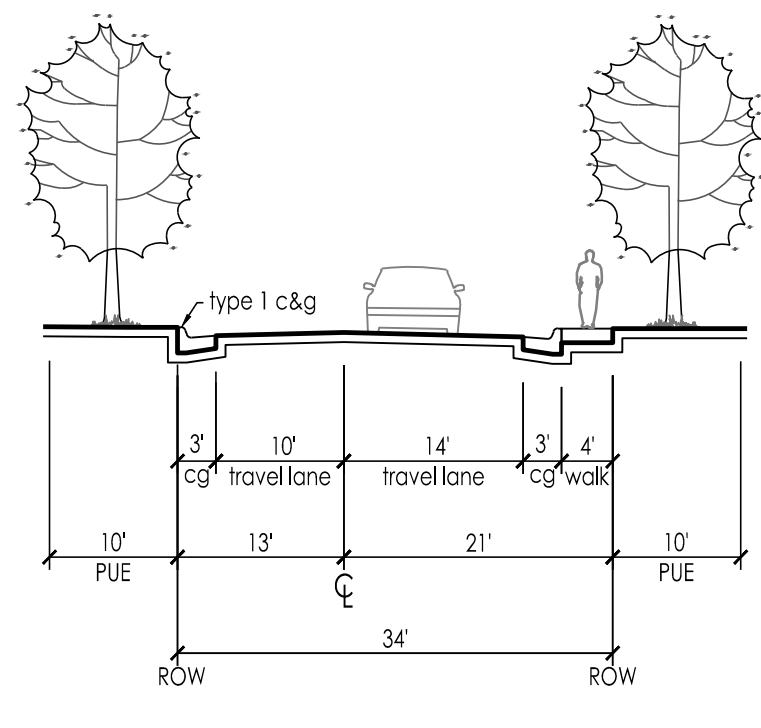

**E MINOR RESIDENTIAL STREET**  
(NO PARKING WEST SIDE)  
n.t.s.

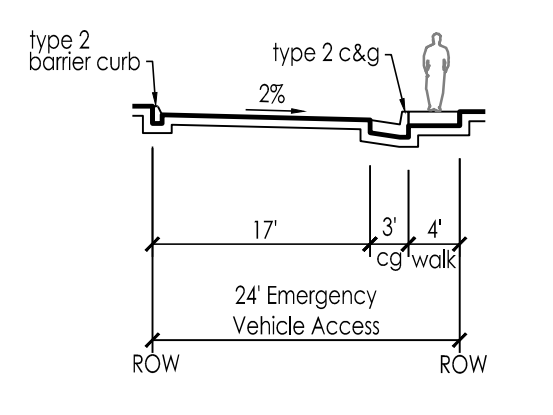

**F EMERGENCY VEHICLE ACCESS**  
n.t.s.

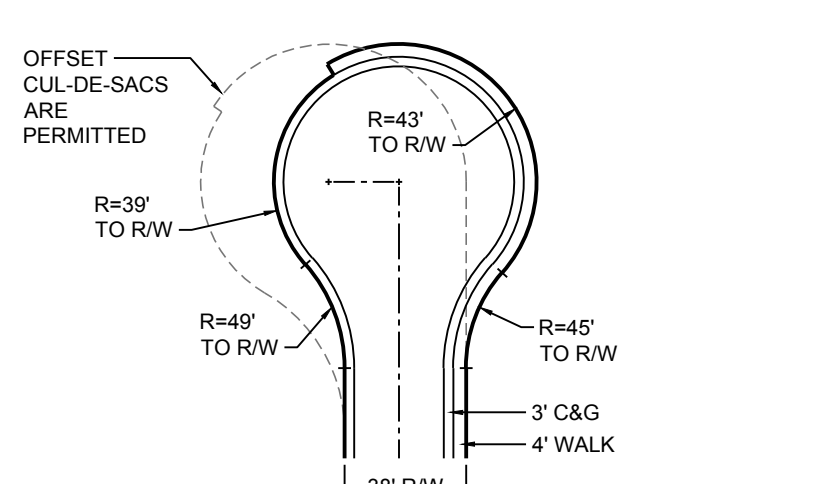

**STANDARD CUL-DE-SAC**  
(CITY OF ROSEVILLE STD. DWG ST-14 & 15)  
n.t.s.

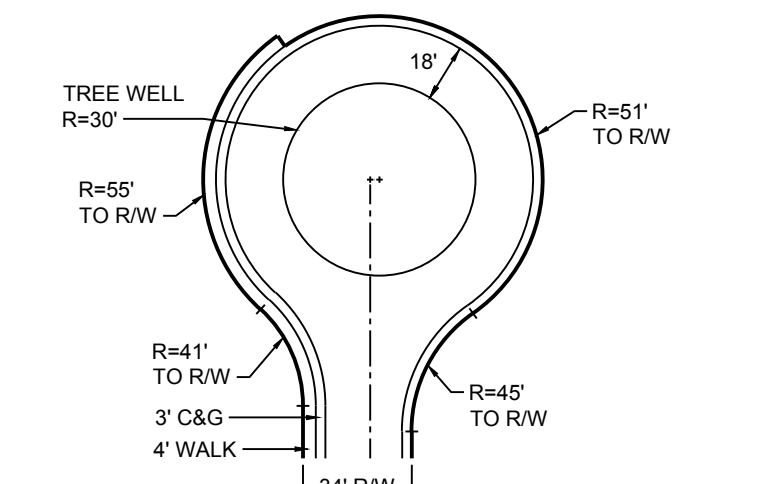

**MODIFIED CUL-DE-SAC**  
n.t.s.

PARCEL SUMMARY TABLE			
Parcel	Acres	Units	Lot Size (sq ft)
Sierra View (LDR)	15.30 ac.	75 du	60' x 65'
<b>Parks, Open Space &amp; Landscape</b>			
Lot A (Landscape)	0.66 ac.		
Lot B (Landscape/Detention)	1.46 ac.		
Lot C (Landscape/Detention)	0.41 ac.		
Lot D (Landscape/Detention)	0.21 ac.		
Lot E (Landscape)	0.01 ac.		
Lot F (Park)	1.19 ac.		
Lot G (Landscape/Detention)	0.77 ac.		
Lot H (Open Space)	2.77 ac.		
Lot I (Landscape)	0.17 ac.		
Lot J (Landscape)	0.12 ac.		
Lot K (Landscape)	0.03 ac.		
Subtotal	7.80 ac.		
<b>TOTAL</b>	<b>23.10 ac.</b>	<b>75 du</b>	

COVER SHEET  
TENTATIVE SUBDIVISION MAP  
**SIERRA VIEW**



SEE SHEET 2

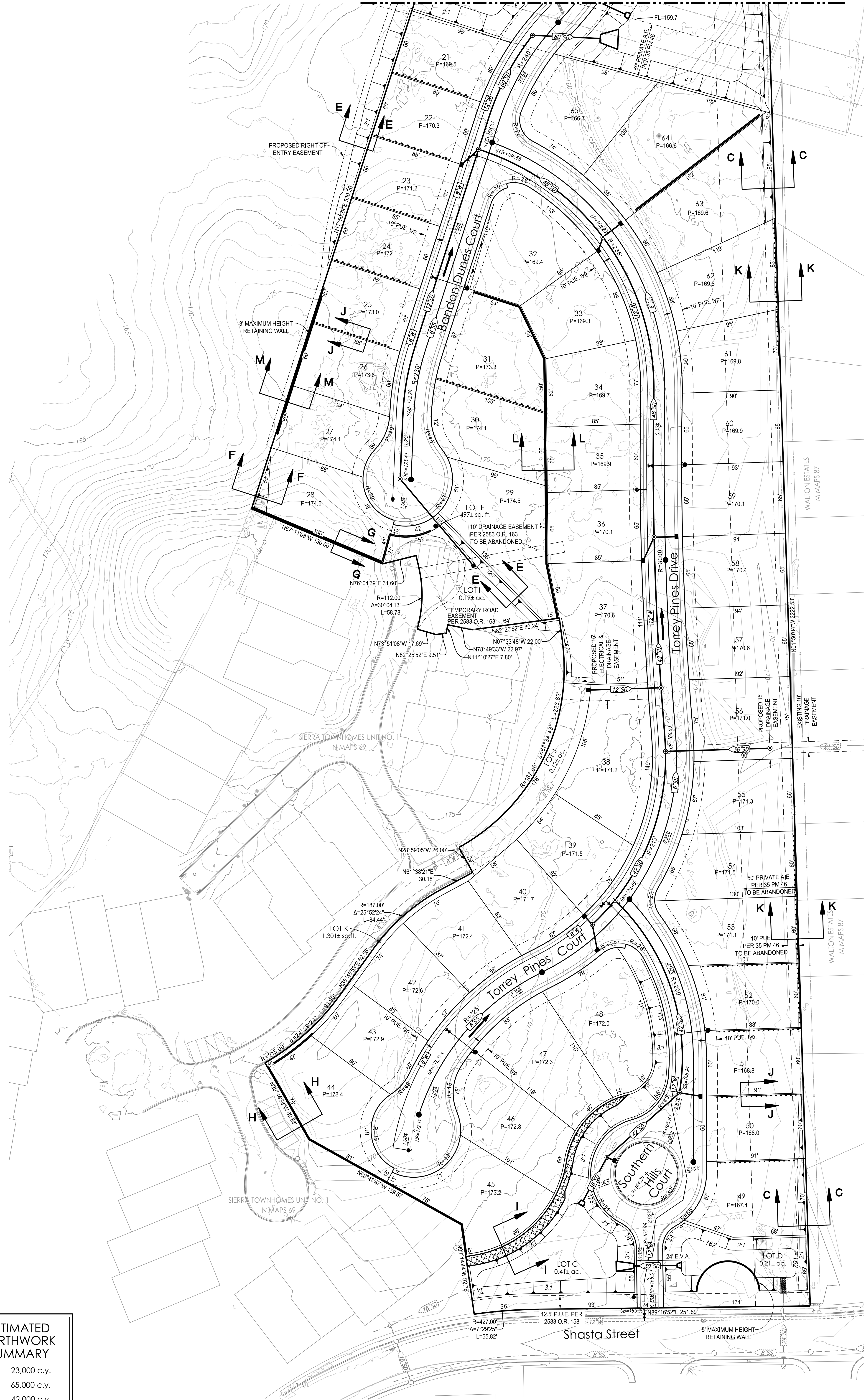

PROPOSED	DESCRIPTION	EXISTING
	SANITARY SEWER PIPE	
	SANITARY SEWER MANHOLE	
	WATER LINE	
	RECYCLED WATER LINE	
	GATE VALVE	
	FIRE HYDRANT	
	BLOW-OFF VALVE	
	STORM DRAIN PIPE	
	STORM DRAIN MANHOLE	
	DROP INLET	
	STORMWATER FACILITY	
	PAD GRADE	
	OVERLAND RELEASE FOR DRAINAGE	
	MASONRY RETAINING WALL	
	WOOD RETAINING WALL	
	ROCKERY RETAINING WALL	
	CLASS III (REAR DRAINING LOTS)	

- ### UTILITY NOTES
- ALL EXISTING UTILITY LOCATIONS SHOWN ARE APPROXIMATE.
  - UTILITIES MAY BE PHASED DEPENDING UPON THE DEVELOPMENT SEQUENCE OF THE PROJECT, SUBJECT TO THE REVIEW OF THE CITY OF ROSEVILLE.
  - THE SIZE AND LOCATION OF PROPOSED WATER, RECYCLED WATER, SEWER, AND STORM DRAINAGE INFRASTRUCTURE IS SUBJECT TO CHANGE DURING FINAL DESIGN, SUBJECT TO REVIEW AND APPROVAL BY THE CITY OF ROSEVILLE WITH IMPROVEMENT PLANS.
  - ANY OFFSITE GRADING SHALL REQUIRE RIGHT OF ENTRY FROM ADJOINING PROPERTY OWNERS. IF A RIGHT OF ENTRY CANNOT BE OBTAINED, RETAINING WALLS ALONG PROPERTY LINES ARE TO BE CONSTRUCTED AS SHOWN HEREON.
  - UNLESS OTHERWISE NOTED, ALL LOTS ARE TO HAVE CLASS 1 LOT DRAINAGE AS SUCH, 2% SWALES, YARD DRAINS, AND UNDERGROUND PIPE SYSTEMS WITH BUBBLE UPS SHALL BE IMPLEMENTED IN LIEU OF 1% MINIMUM SWALES. AN OVERLAND RELEASE TO THE STREET RIGHT-OF-WAY SHALL BE INCLUDED AS PART OF THE FINISHED LOT GRADING DESIGN TO PRECLUDE ANY FLOODING AGAINST FUTURE BUILDING FOUNDATION. POSITIVE DRAINAGE AWAY FROM THE BUILDING AT A SLOPE OF 5% MINIMUM SHALL BE PROVIDED, CONSISTENT WITH SECTION 2304.11 OF THE CALIFORNIA BLDG CODE.

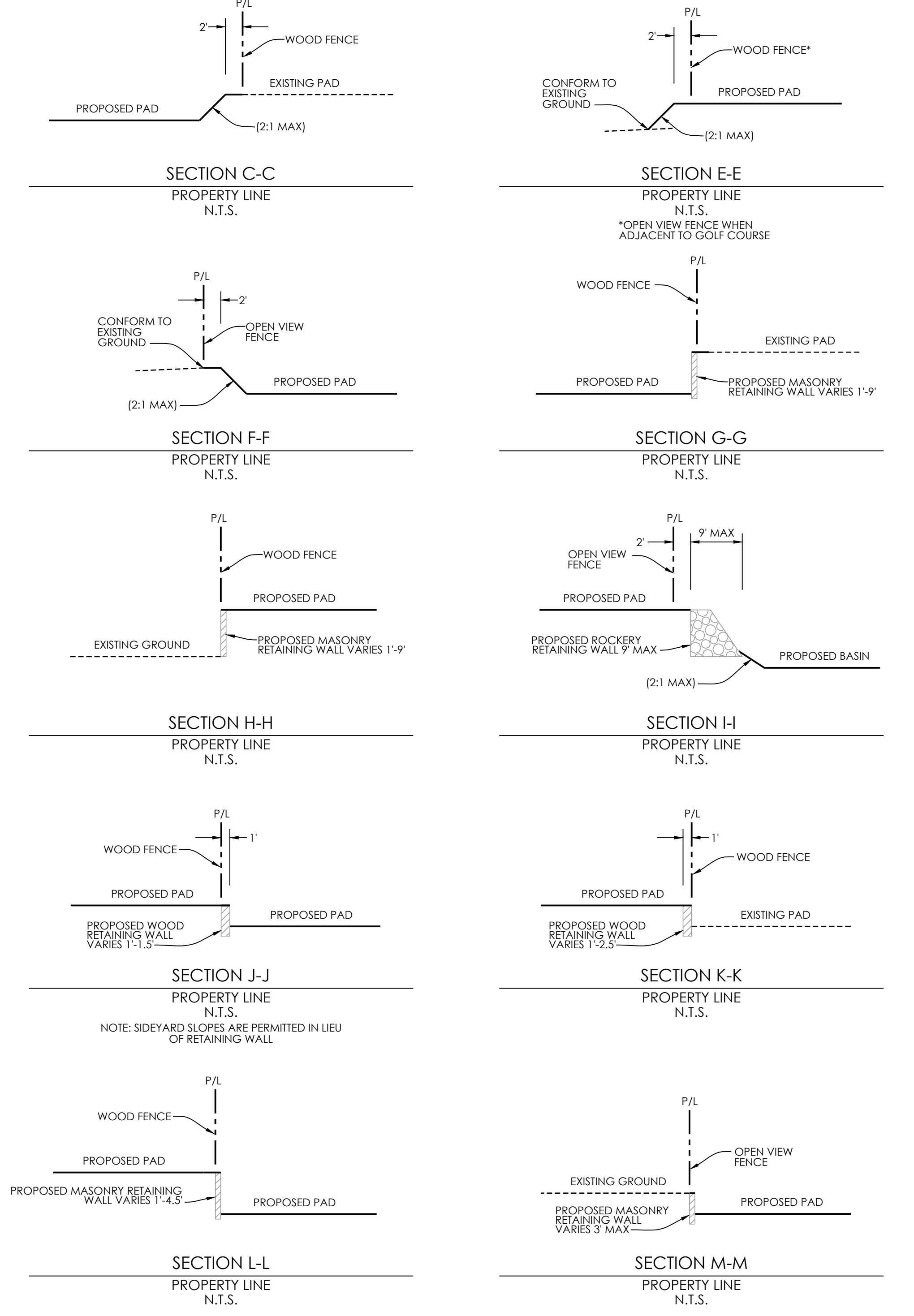

ESTIMATED EARTHWORK SUMMARY	
CUT:	23,000 c.y.
FILL:	65,000 c.y.
NET:	42,000 c.y.

SCALE: 1"=40'  
**CONCEPTUAL GRADING, DRAINAGE AND UTILITIES TENTATIVE SUBDIVISION MAP**  
**SIERRA VIEW**

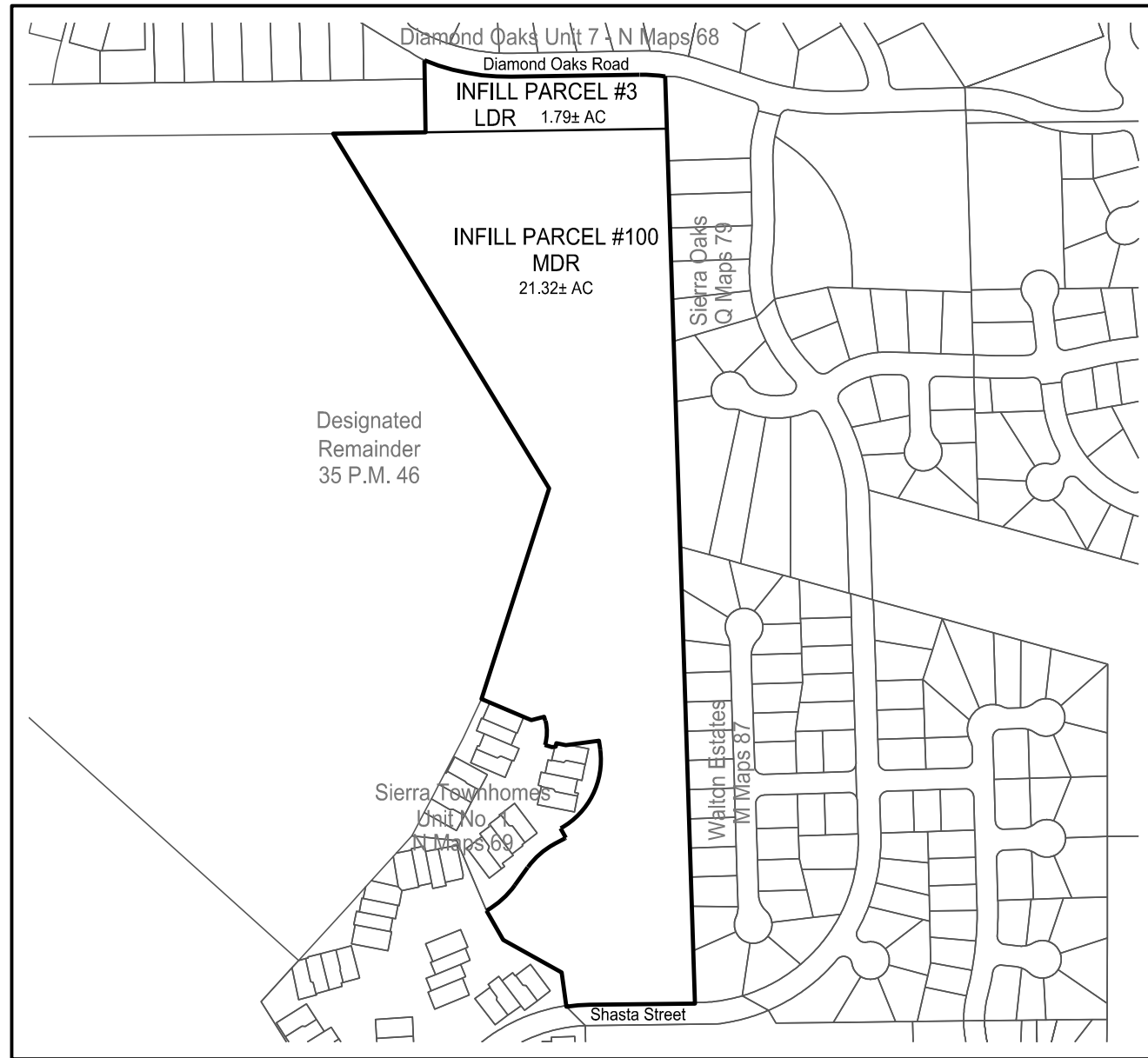

EXISTING LAND USE

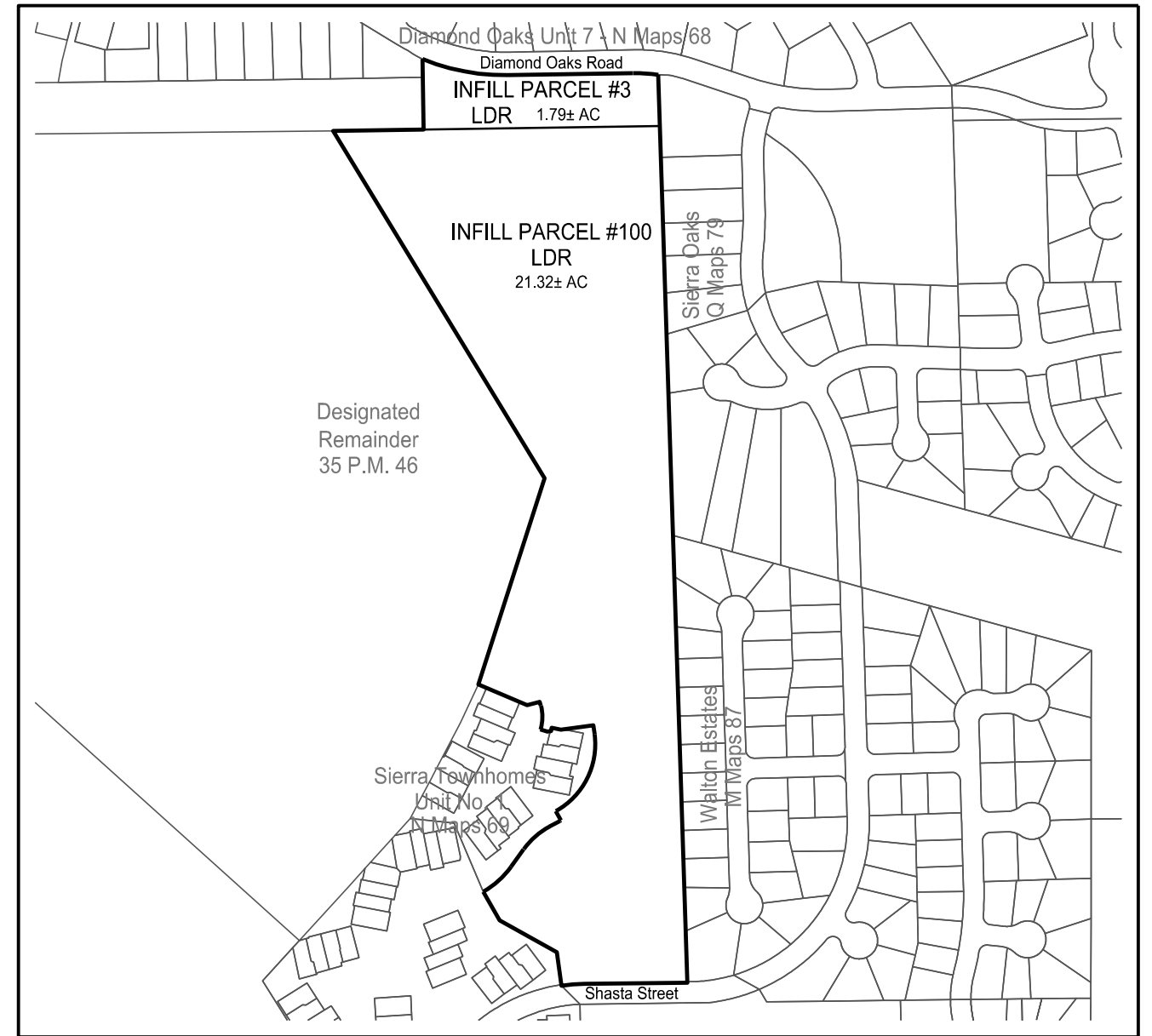

PROPOSED LAND USE

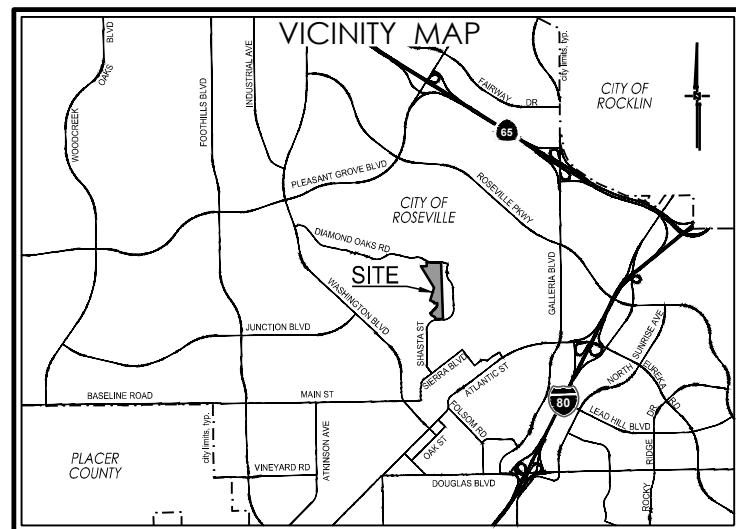

Existing Land Use			Proposed Land Use		
Parcel	Land Use	Acres	Parcel	Land Use	Acres
Infill Parcel #3	LDR	1.79 ac.	Infill Parcel #3	LDR	1.79 ac.
Infill Parcel #100	MDR	21.31 ac.	Infill Parcel #100	LDR	21.31 ac.
<b>TOTAL</b>		<b>23.10 ac.</b>	<b>TOTAL</b>		<b>23.10 ac.</b>

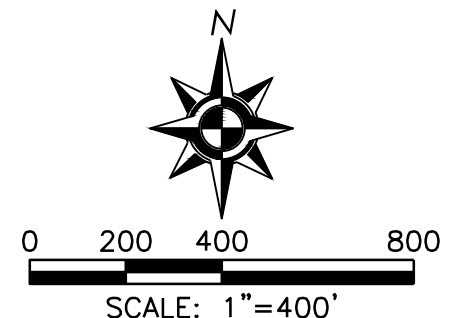

GENERAL PLAN AMENDMENT  
**SIERRA VIEW**

Roseville, CA

October 29, 2021



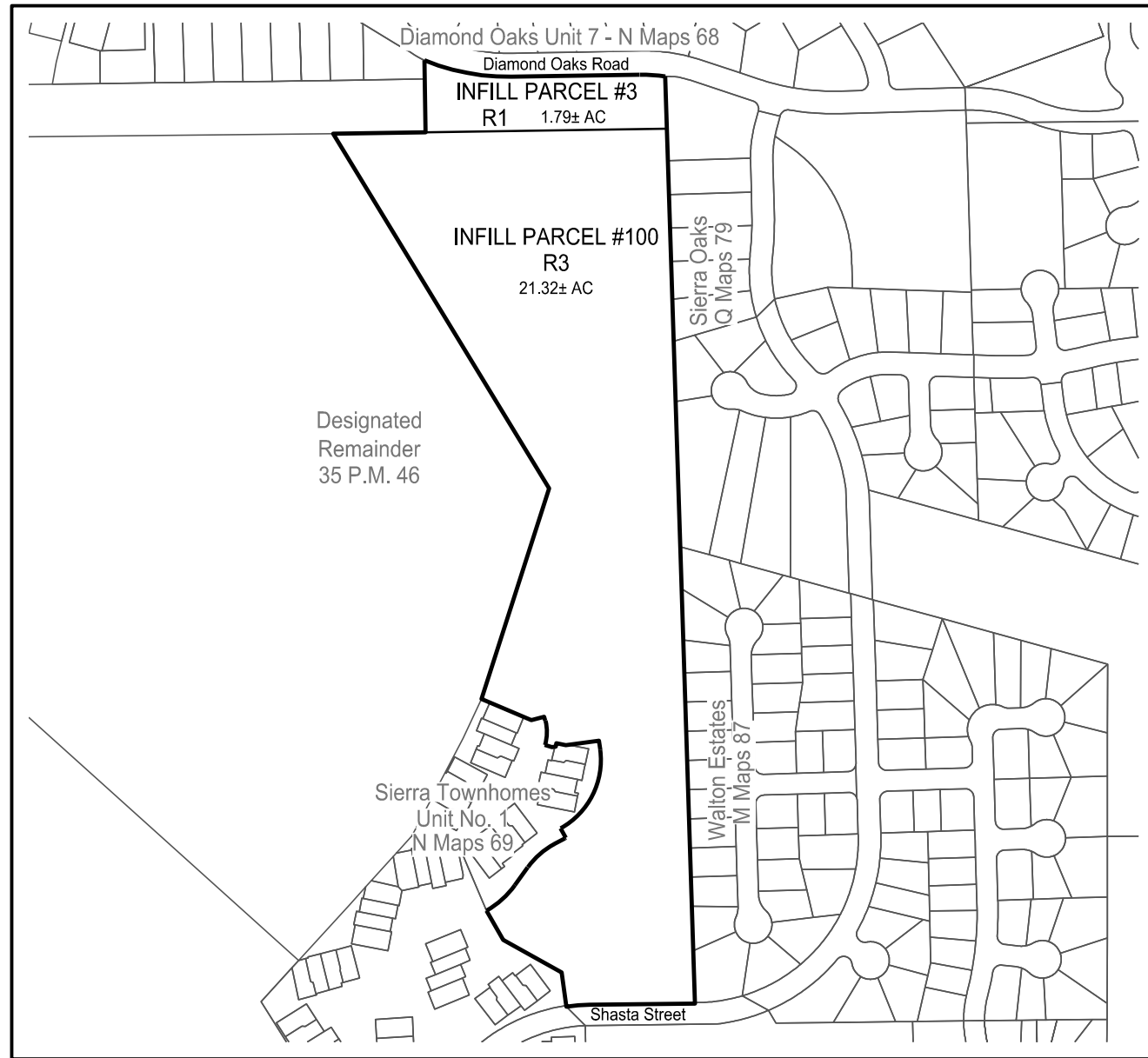

EXISTING ZONING

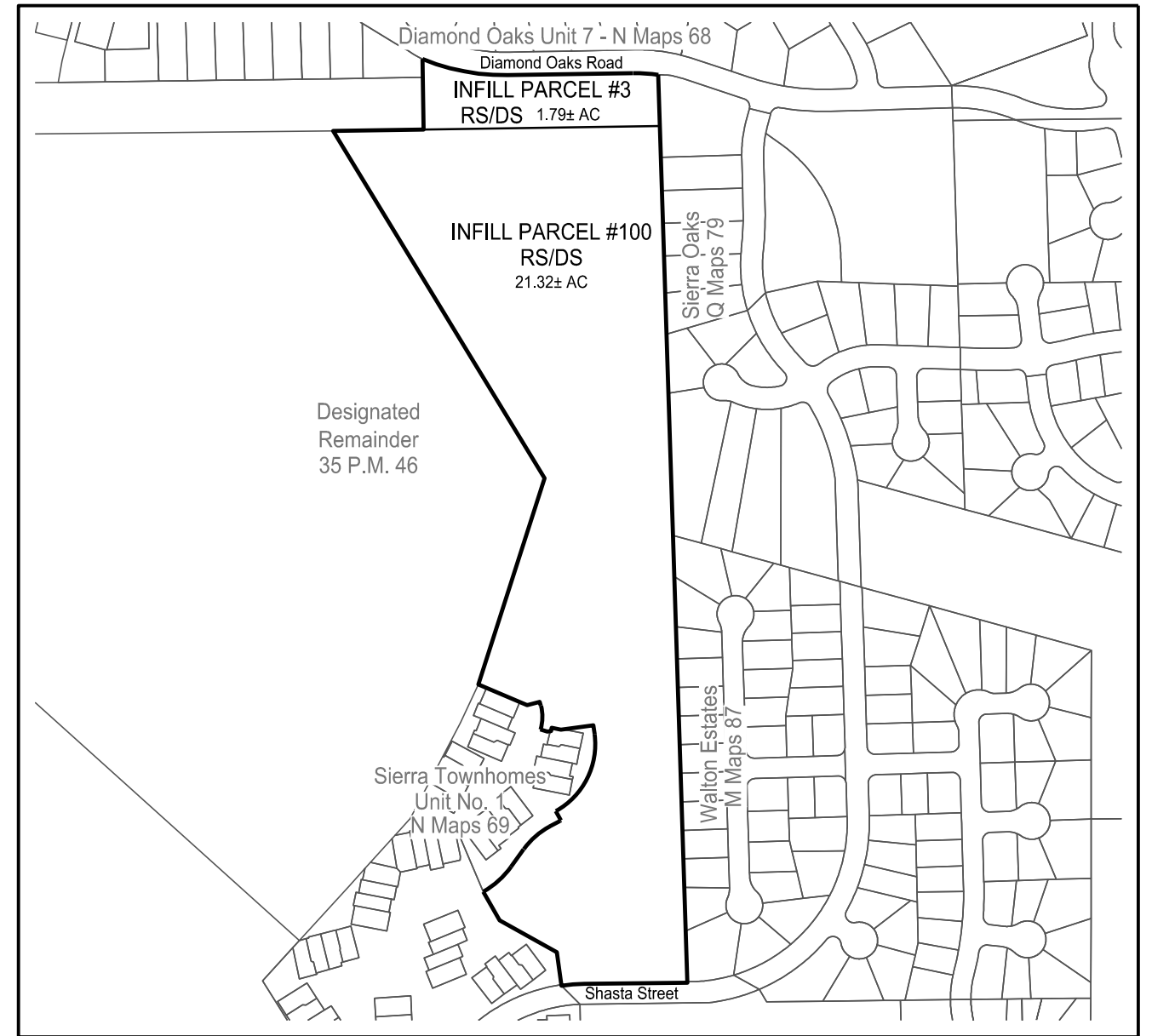

PROPOSED ZONING

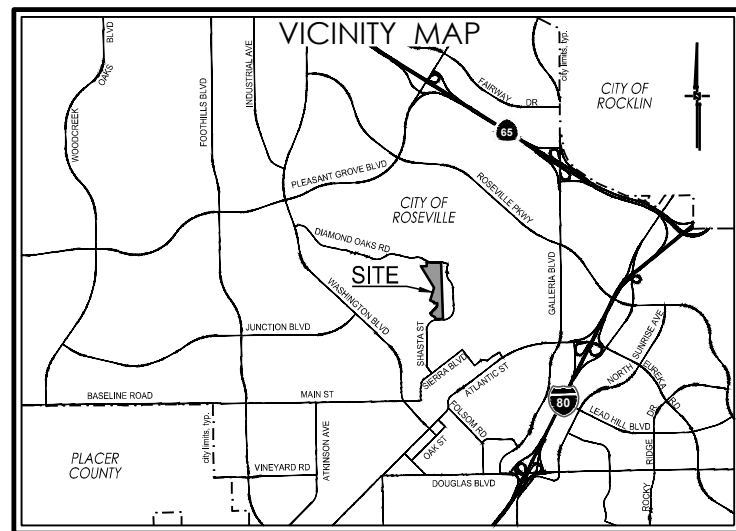

Existing Zoning			Proposed Zoning		
Parcel	Zoning	Acres	Parcel	Zoning	Acres
Infill Parcel #3	R1	1.79 ac.	Infill Parcel #3	RS/DS	1.79 ac.
Infill Parcel #100	R3	21.31 ac.	Infill Parcel #100	RS/DS	21.31 ac.
<b>TOTAL</b>		<b>23.10 ac.</b>	<b>TOTAL</b>		<b>23.10 ac.</b>

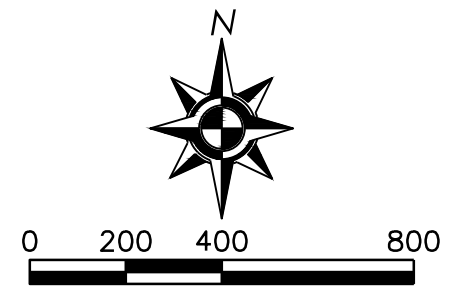

REZONE EXHIBIT

# SIERRA VIEW

Roseville, CA

October 29, 2021





TREE REMOVAL INFORMATION

● TREE# EXISTING OAK TREE - TO REMAIN     
 X TREE# PROPOSED FOR REMOVAL     
 ⊗ TREE# ARBORIST RECOMMENDED REMOVAL     
 ● TREE# EXISTING OAK TREE TO REMAIN (IMPACTED)

Tag #	Common Name	Species	Multi-Trunks (n)	DBH (in)	Measured Canopy Radius	Disposition
1	Coast Live Oak	Quercus agrifolia	17	12		To remain.
424	Blue Oak	Quercus douglasii	11	10		Proposed Removal.
6501	Blue Oak	Quercus douglasii	38	33		Proposed Removal.
6502	Blue Oak	Quercus douglasii	41	30		To remain.
6503	Blue Oak	Quercus douglasii	35	24		Proposed Removal.
6504	Blue Oak	Quercus douglasii	3.4	7	4	Proposed Removal.
6505	Blue Oak	Quercus douglasii	26	15		To remain.
6506	Blue Oak	Quercus douglasii	36	30		To remain. (impacted)
6507	Blue Oak	Quercus douglasii	31	27		To remain. (impacted)
6508	Blue Oak	Quercus douglasii	35	30		Proposed Removal.
6509	Blue Oak	Quercus douglasii	35	24		Proposed Removal.
6510	Blue Oak	Quercus douglasii	28	27		Proposed Removal.
6511	Blue Oak	Quercus douglasii	34	24		Proposed Removal.
6512	Coast Live Oak	Quercus agrifolia	8	6		Proposed Removal.
6513	Coast Live Oak	Quercus agrifolia	15	7		Proposed Removal.
6514	Coast Live Oak	Quercus agrifolia	15	8		Proposed Removal.
6515	Blue Oak	Quercus douglasii	8	5		Proposed Removal.
6516	Blue Oak	Quercus douglasii	6	4		Proposed Removal.
6517	Blue Oak	Quercus douglasii	0	0		Dead
6518	Blue Oak	Quercus douglasii	24	36		Proposed Removal.
6519	Blue Oak	Quercus douglasii	9	5		Proposed Removal.
6520	Blue Oak	Quercus douglasii	11	12		Proposed Removal.
6521	Blue Oak	Quercus douglasii	2.3, 3.3	11	4	Proposed Removal.
6522	Blue Oak	Quercus douglasii	44	23		Proposed Removal.
6523	Blue Oak	Quercus douglasii	3.4	7	4	Proposed Removal.
6524	Blue Oak	Quercus douglasii	13	9		Proposed Removal.
6525	Blue Oak	Quercus douglasii	8	6		Proposed Removal.
6526	Blue Oak	Quercus douglasii	8	6		Proposed Removal.
6527	Blue Oak	Quercus douglasii	10	7		Proposed Removal.
6528	Blue Oak	Quercus douglasii	10	7		Proposed Removal.
6529	Blue Oak	Quercus douglasii	6	10		Proposed Removal.
6530	Blue Oak	Quercus douglasii	49	36		Proposed Removal.
6531	Blue Oak	Quercus douglasii	15	24		Recommend removal.
6532	Blue Oak	Quercus douglasii	11	12		Proposed Removal.
6533	Blue Oak	Quercus douglasii	39	30		Proposed Removal.
6534	Blue Oak	Quercus douglasii	12	9		Proposed Removal.
6535	Blue Oak	Quercus douglasii	34	24		Proposed Removal.
6536	Blue Oak	Quercus douglasii	10	9		Proposed Removal.
6537	Blue Oak	Quercus douglasii	36	30		Recommend removal.
6538	Blue Oak	Quercus douglasii	30	18		Proposed Removal.
6539	Blue Oak	Quercus douglasii	5.5	10	6	Proposed Removal.
6540	Blue Oak	Quercus douglasii	10	12		Proposed Removal.
6541	Blue Oak	Quercus douglasii	30	30		Proposed Removal.
6542	Blue Oak	Quercus douglasii	36	18		Proposed Removal.
6543	Blue Oak	Quercus douglasii	7	6		Proposed Removal.
6544	Blue Oak	Quercus douglasii	29	27		Proposed Removal.
6545	Blue Oak	Quercus douglasii	34	29		Recommend removal.
6546	Blue Oak	Quercus douglasii	8	15		Proposed Removal.
6547	Blue Oak	Quercus douglasii	7.8	15	12	Proposed Removal.
6548	Blue Oak	Quercus douglasii	12	9		Proposed Removal.
6549	Blue Oak	Quercus douglasii	10.11, 12	32	12	Proposed Removal.
6550	Blue Oak	Quercus douglasii	7	9		To remain. (impacted)
6551	Blue Oak	Quercus douglasii	34	21		To remain.
6552	Blue Oak	Quercus douglasii	27	33		To remain.
6553	Blue Oak	Quercus douglasii	40	21		To remain.
6554	Blue Oak	Quercus douglasii	7	5		To remain. (impacted)
6555	Blue Oak	Quercus douglasii	10	9		Proposed Removal.
6556	Blue Oak	Quercus douglasii	13	12		Proposed Removal.
6557	Blue Oak	Quercus douglasii	6	8		Proposed Removal.
6558	Blue Oak	Quercus douglasii	6	7		Proposed Removal.
6559	Interior Live Oak	Quercus wislizeni	17	21		Proposed Removal.
6560	Blue Oak	Quercus douglasii	15	12		Proposed Removal.
6561	Blue Oak	Quercus douglasii	14	18		Proposed Removal.
6562	Blue Oak	Quercus douglasii	5.6	11	12	Proposed Removal.
6563	Blue Oak	Quercus douglasii	4, 7.8, 11	30	18	Proposed Removal.
6564	Valley Oak	Quercus lobata	18	18		Proposed Removal.
6565	Blue Oak	Quercus douglasii	8	6		Proposed Removal.
6566	Blue Oak	Quercus douglasii	10	10		Proposed Removal.
6567	Blue Oak	Quercus douglasii	7	5		Proposed Removal.
6568	Interior Live Oak	Quercus wislizeni	20	15		Proposed Removal.
6569	Blue Oak	Quercus douglasii	7.12	19	12	To remain.
6570	Blue Oak	Quercus douglasii	12	16		To remain.
6571	Blue Oak	Quercus douglasii	9	6		To remain.
6572	Blue Oak	Quercus douglasii	9	6		To remain. (impacted)
6573	Blue Oak	Quercus douglasii	13	10		Proposed Removal.
6574	Blue Oak	Quercus douglasii	8	15		Proposed Removal.
6575	Coast Live Oak	Quercus agrifolia	11	18		Proposed Removal.
6576	Blue Oak	Quercus douglasii	10	8		To remain.
6577	Blue Oak	Quercus douglasii	7	5		To remain.
6578	Blue Oak	Quercus douglasii	30	30		Proposed Removal.
6579	Blue Oak	Quercus douglasii	21	21		Proposed Removal.
6580	Blue Oak	Quercus douglasii	41	33		Proposed Removal.
6581	Blue Oak	Quercus douglasii	36	24		Proposed Removal.
6583	Blue Oak	Quercus douglasii	5.7	12	8	To remain. (impacted)
6584	Coast Live Oak	Quercus agrifolia	7, 7.8	22	9	Proposed Removal.
6585	Blue Oak	Quercus douglasii	7	10		To remain. (impacted)
6586	Blue Oak	Quercus douglasii	8	6		To remain.
6587	Blue Oak	Quercus douglasii	6	6		To remain.
6588	Coast Live Oak	Quercus agrifolia	10	9		To remain. (impacted)
6589	Blue Oak	Quercus douglasii	21	18		To remain. (impacted)
6590	Blue Oak	Quercus douglasii	22	12		To remain.
6591	Blue Oak	Quercus douglasii	14	15		Proposed Removal.
6592	Blue Oak	Quercus douglasii	7	10		Proposed Removal.
6593	Blue Oak	Quercus douglasii	6	9		Proposed Removal.
6594	Blue Oak	Quercus douglasii	7	8		Proposed Removal.
6595	Blue Oak	Quercus douglasii	10	9		Proposed Removal.
6596	Blue Oak	Quercus douglasii	41	23		Proposed Removal.
6597	Blue Oak	Quercus douglasii	11	9		Proposed Removal.
6598	Blue Oak	Quercus douglasii	4.4, 6	14	8	Proposed Removal.
6599	Blue Oak	Quercus douglasii	7.8	15	10	To remain. (impacted)
6600	Blue Oak	Quercus douglasii	4.4, 5	13	9	To remain. (impacted)
6601	Blue Oak	Quercus douglasii	9	6		To remain.
6602	Blue Oak	Quercus douglasii	5.5	10	9	To remain. (impacted)
6603	Blue Oak	Quercus douglasii	10, 11	21	7	Proposed Removal.
6604	Blue Oak	Quercus douglasii	6	5		Proposed Removal.
6605	Blue Oak	Quercus douglasii	29	18		Recommend removal.
6606	Blue Oak	Quercus douglasii	11	5		Proposed Removal.
6607	Blue Oak	Quercus douglasii	45	36		Proposed Removal.

Tag #	Common Name	Species	Multi-Trunks (n)	DBH (in)	Measured Canopy Radius	Disposition
6608	Blue Oak	Quercus douglasii	21	21	40	Recommend removal.
6609	Blue Oak	Quercus douglasii	4.4	8	3	Proposed Removal.
6610	Blue Oak	Quercus douglasii	8	7		Proposed Removal.
6611	Blue Oak	Quercus douglasii	6	5		Proposed Removal.
6612	Blue Oak	Quercus douglasii	7	7		Proposed Removal.
6613	Blue Oak	Quercus douglasii	7	5		Proposed Removal.
6614	Blue Oak	Quercus douglasii	12	5		Proposed Removal.
6615	Blue Oak	Quercus douglasii	7	10		Proposed Removal.
6616	Blue Oak	Quercus douglasii	4.5	9	4	Proposed Removal.
6617	Blue Oak	Quercus douglasii	3, 4.4, 4	15	9	Proposed Removal.
6618	Blue Oak	Quercus douglasii	33	8		To remain. (impacted)
6619	Blue Oak	Quercus douglasii	21	15		Proposed Removal.
6620	Blue Oak	Quercus douglasii	11	10		Recommend removal.
6621	Blue Oak	Quercus douglasii	7	5		To remain. (impacted)
6622	Blue Oak	Quercus douglasii	6.8	14	6	To remain.
6623	Blue Oak	Quercus douglasii	7	6		To remain. (impacted)
6624	Blue Oak	Quercus douglasii	6	5		Proposed Removal.
6625	Blue Oak	Quercus douglasii	9	6		Proposed Removal.
6626	Blue Oak	Quercus douglasii	9	7		Proposed Removal.
6627	Blue Oak	Quercus douglasii	6	5		Proposed Removal.
6628	Blue Oak	Quercus douglasii	17	12		Proposed Removal.
6629	Blue Oak	Quercus douglasii	8	8		Proposed Removal.
6630	Blue Oak	Quercus douglasii	8	9		Proposed Removal.
6631	Blue Oak	Quercus douglasii	8	6		Proposed Removal.
6632	Blue Oak	Quercus douglasii	10	12		Proposed Removal.
6633	Blue Oak	Quercus douglasii	7	4		Proposed Removal.
6634	Blue Oak	Quercus douglasii	7	6		Proposed Removal.
6635	Blue Oak	Quercus douglasii	16	10		Proposed Removal.
6636	Blue Oak	Quercus douglasii	9	7		Proposed Removal.
6637	Interior Live Oak	Quercus wislizeni	6	5		Proposed Removal.
6638	Blue Oak	Quercus douglasii	10	18		Proposed Removal.
6639	Blue Oak	Quercus douglasii	10	15		Proposed Removal.
6640	Blue Oak	Quercus douglasii	6	4		To remain.
6641	Blue Oak	Quercus douglasii	5.7	12	8	To remain.
6642	Blue Oak	Quercus douglasii	21	12		To remain.
6643	Blue Oak	Quercus douglasii	15	9		To remain.
6644	Blue Oak	Quercus douglasii	9	8		To remain.
6645	Blue Oak	Quercus douglasii	8	10		To remain.
6646	Blue Oak	Quercus douglasii	9	6		To remain.
6647	Blue Oak	Quercus douglasii	8.10	18	12	To remain.
6648	Blue Oak	Quercus douglasii	10	12		To remain.
6649	Blue Oak	Quercus douglasii	7	5		To remain.
6650	Blue Oak	Quercus douglasii	10	9		To remain.
6651	Blue Oak	Quercus douglasii	10	7		To remain.
6652	Blue Oak	Quercus douglasii	6	4		To remain. (impacted)
6653	Blue Oak	Quercus douglasii	15	12		To remain.
6654	Blue Oak	Quercus douglasii	8, 10, 12, 12	42	24	Recommend removal.
6655	Blue Oak	Quercus douglasii	10	9		To remain.
6656	Blue Oak	Quercus douglasii	6	4		To remain.
6657	Blue Oak	Quercus douglasii	8	5		To remain.
6658	Blue Oak	Quercus douglasii	4.5	9	4	To remain.
6659	Coast Live Oak	Quercus agrifolia	3.6, 7	16	10	Proposed Removal.
6660	Blue Oak	Quercus douglasii	14	18		To remain.
6661	Blue Oak	Quercus douglasii	13	15		To remain.
6662	Blue Oak	Quercus douglasii	11	12		To remain.
6663	Blue Oak	Quercus douglasii	13	12		To remain.
6664	Blue Oak	Quercus douglasii	25	21		To remain.
6665	Blue Oak	Quercus douglasii	42	24		Recommend removal.
6666	Blue Oak	Quercus douglasii	8.11	19	18	To remain.
6667	Blue Oak	Quercus douglasii	9	7		To remain.
6668	Blue Oak	Quercus douglasii	12	12		To remain.
6669	Blue Oak	Quercus douglasii	17	15		To remain.
6670	Coast Live Oak	Quercus agrifolia	13	10		Recommend removal.
6671	Blue Oak	Quercus douglasii	13	12		To remain.
6672	Blue Oak	Quercus douglasii	15	12		To remain.
6673	Blue Oak	Quercus douglasii	33	21		To remain.
6674	Blue Oak	Quercus douglasii	4.5	9	7	To remain.
6675	Blue Oak	Quercus douglasii	20, 30	30	30	To remain.
6676	Blue Oak	Quercus douglasii	25	21		To remain.
6677	Blue Oak	Quercus douglasii	30	21		To remain.
6678	Blue Oak	Quercus douglasii	28	36		To remain.
6679	Blue Oak	Quercus douglasii	9.11	20	9	To remain.
6680	Blue Oak	Quercus douglasii	9.10	19	10	To remain.
6681	Blue Oak	Quercus douglasii	4.4, 4.5	17	7	To remain.
6682	Blue Oak	Quercus douglasii	11	15		To remain.
6683	Blue Oak	Quercus douglasii	11	12		To remain.
6684	Blue Oak	Quercus douglasii	15	12		To remain.
6685	Blue Oak	Quercus douglasii	11	9		To remain.
6686	Blue Oak	Quercus douglasii	17	12		To remain.
6687	Blue Oak	Quercus douglasii	8	9		To remain.
6688	Blue Oak	Quercus douglasii	7.9	16	7	To remain.
6689	Blue Oak	Quercus douglasii	9	7		To remain.
6690	Blue Oak	Quercus douglasii	14	10		To remain.
6691	Blue Oak	Quercus douglasii	8	6		To remain.
6692	Blue Oak	Quercus douglasii	12	16		To remain.
6693	Blue Oak	Quercus douglasii	14	12		To remain.
6694	Blue Oak	Quercus douglasii	19	21		To remain.
6695	Blue Oak	Quercus douglasii	6	5		To remain.
6696	Blue Oak	Quercus douglasii	10	8		To remain.
6697	Blue Oak	Quercus douglasii	17	18		To remain.
6698	Blue Oak	Quercus douglasii	8	9		To remain.
6699	Blue Oak	Quercus douglasii	14	18		To remain.
6700	Blue Oak	Quercus douglasii	12	15		To remain. (impacted)
6701	Blue Oak	Quercus douglasii	15	21		To remain. (impacted)
6702	Blue Oak	Quercus douglasii	3.4	7	7	Proposed Removal.
6703	Blue Oak	Quercus douglasii	16, 17	33	21	Proposed Removal.